

ISA

Philadelphia / Cambridge

BRIAN PHILLIPS

BRIAN@IS-ARCHITECTS.COM

Our work unlocks low-cost housing by exploring the margins of neighborhood boundaries, pro formas, materials, zoning and building codes and non-standard property conditions.



AMBER

ISA



Typical.
Less insulation,
more infiltration,
bigger HVAC system,
higher energy bills.



Passive.
More insulation,
less infiltration,
smaller HVAC system,
lower energy bills.

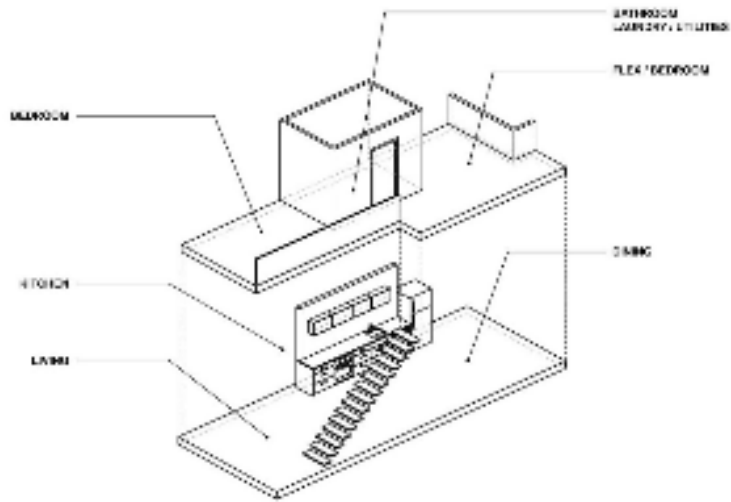
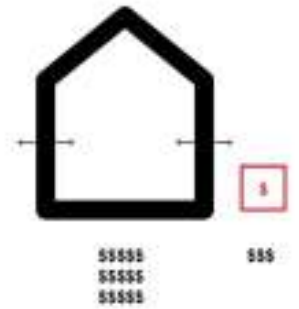







**PHILADELPHIA
FABRIC**



ISA



INFILL



CURB APPEAL

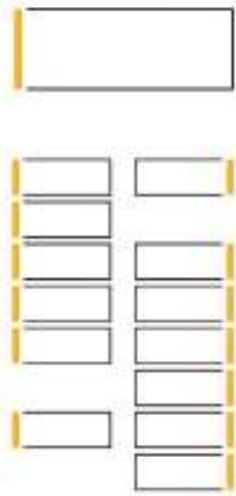

CORE APPEAL

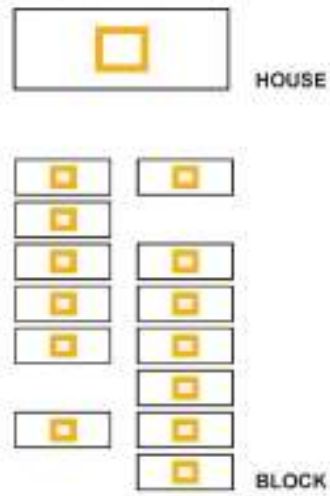

THE WOOD-CLAD CORE ORGANIZES CIRCULATION AROUND A PIECE OF CUSTOM MILLWORK WITHIN A SIMPLE WHITE BOX.

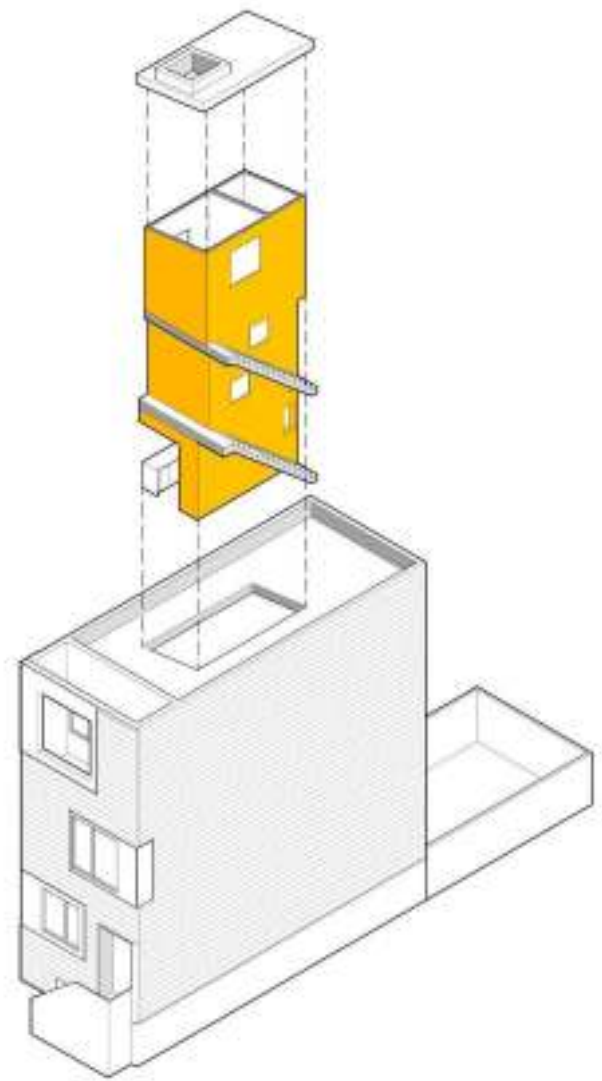







INFILL



CHUNK

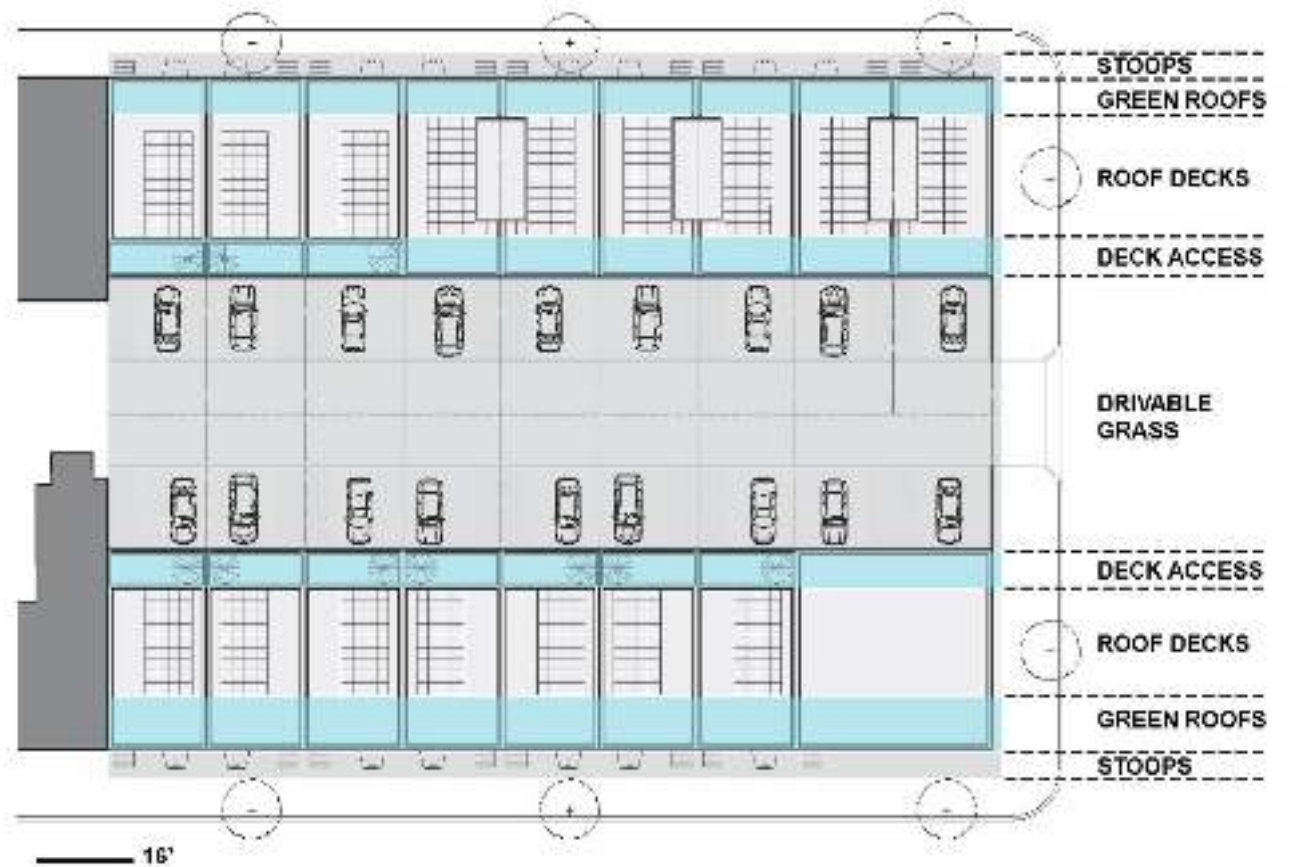
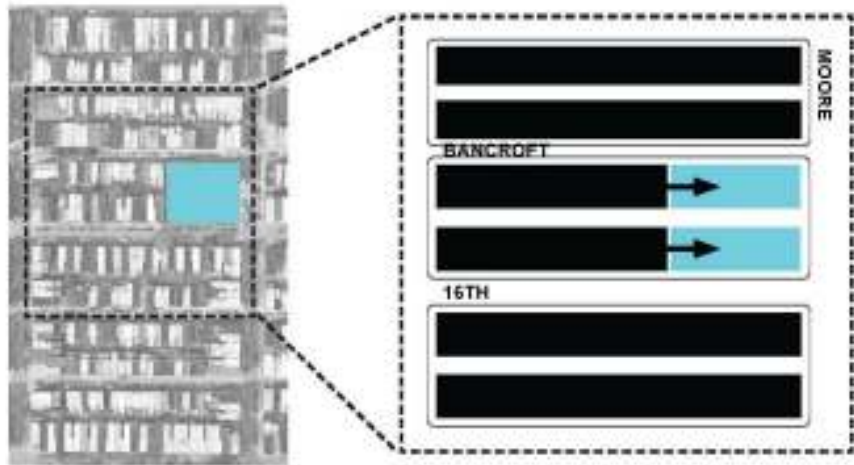

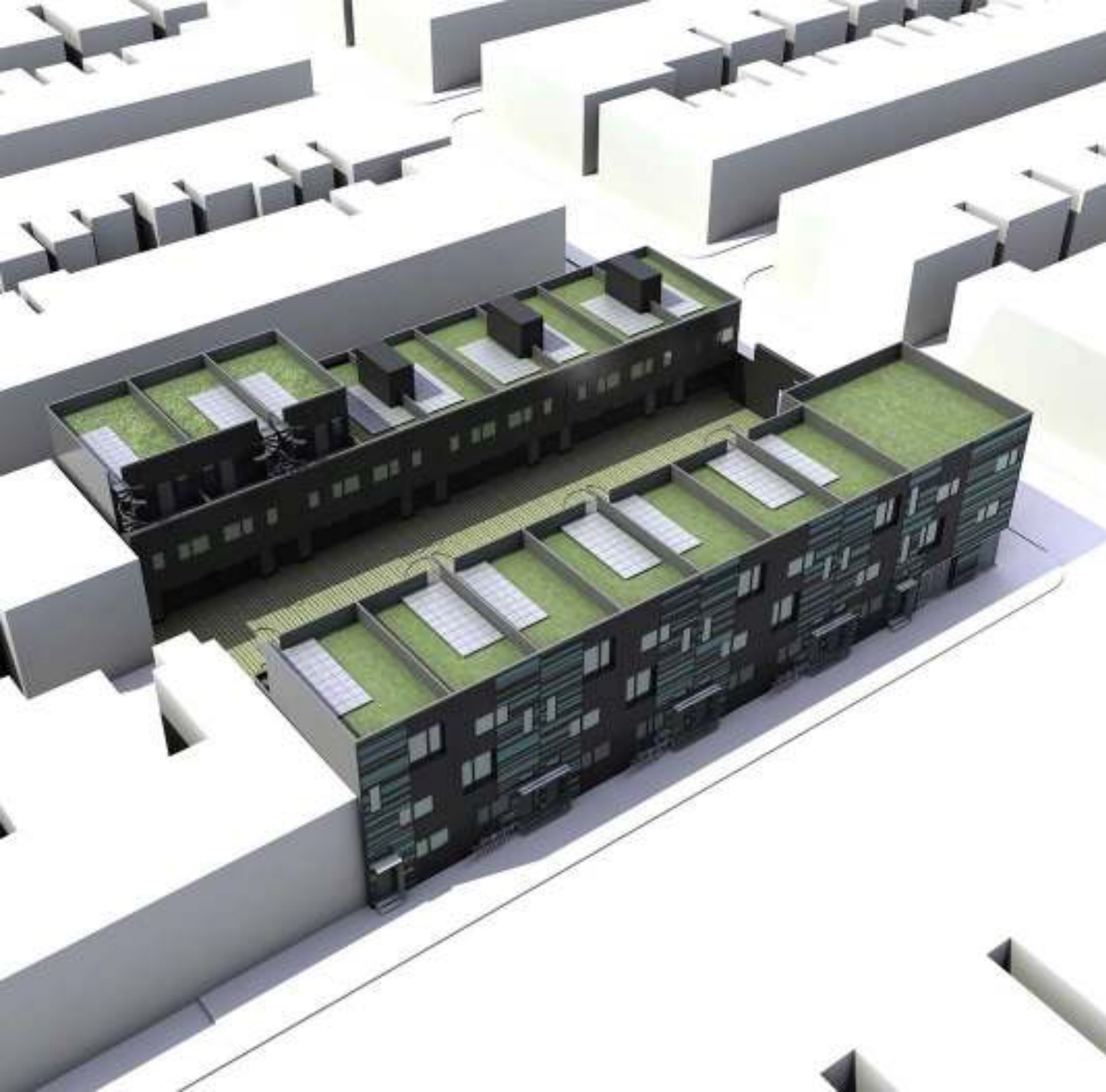

2-STORY



3-STORY



RETAIL + FLATS



MUMMERS PARADE



VERNACULAR FACADE TEXTURE



ISA







INFILL



CHUNK



LEFTOVER



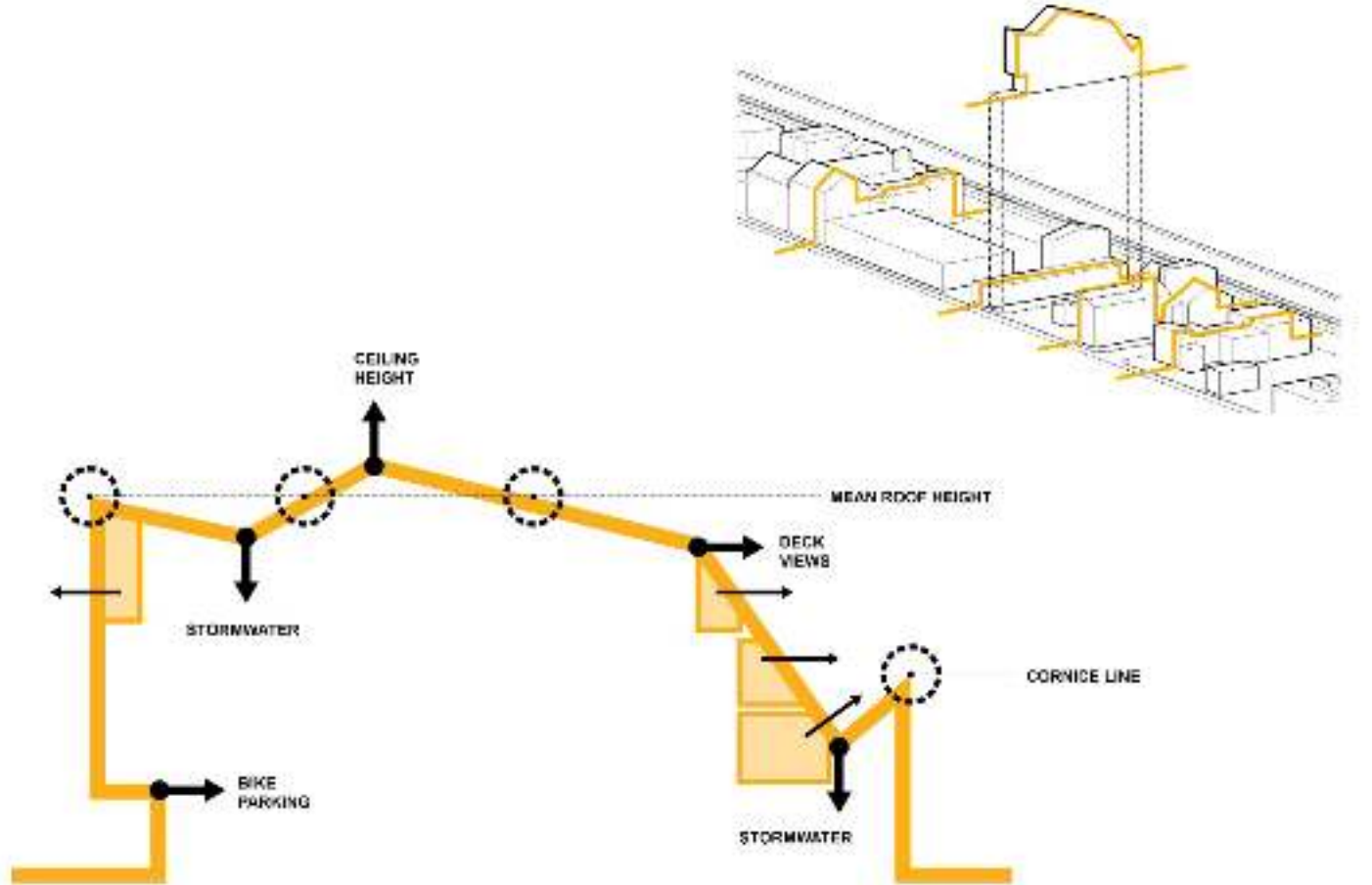







ISA

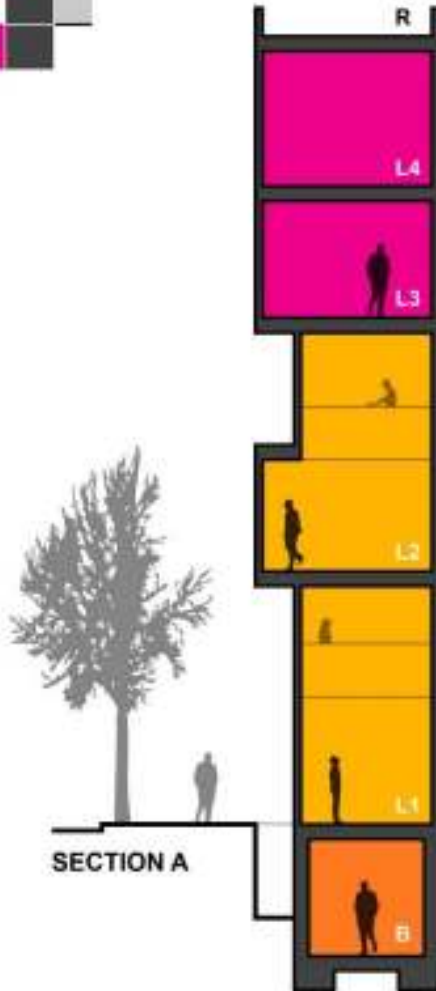
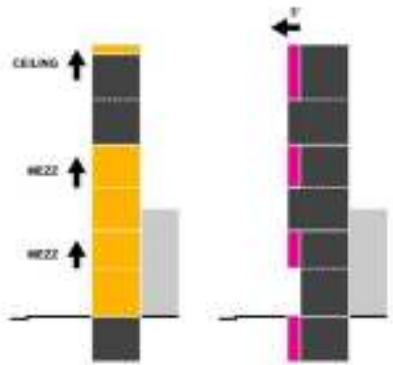

SUPER LEFTOVER !!!

ISA

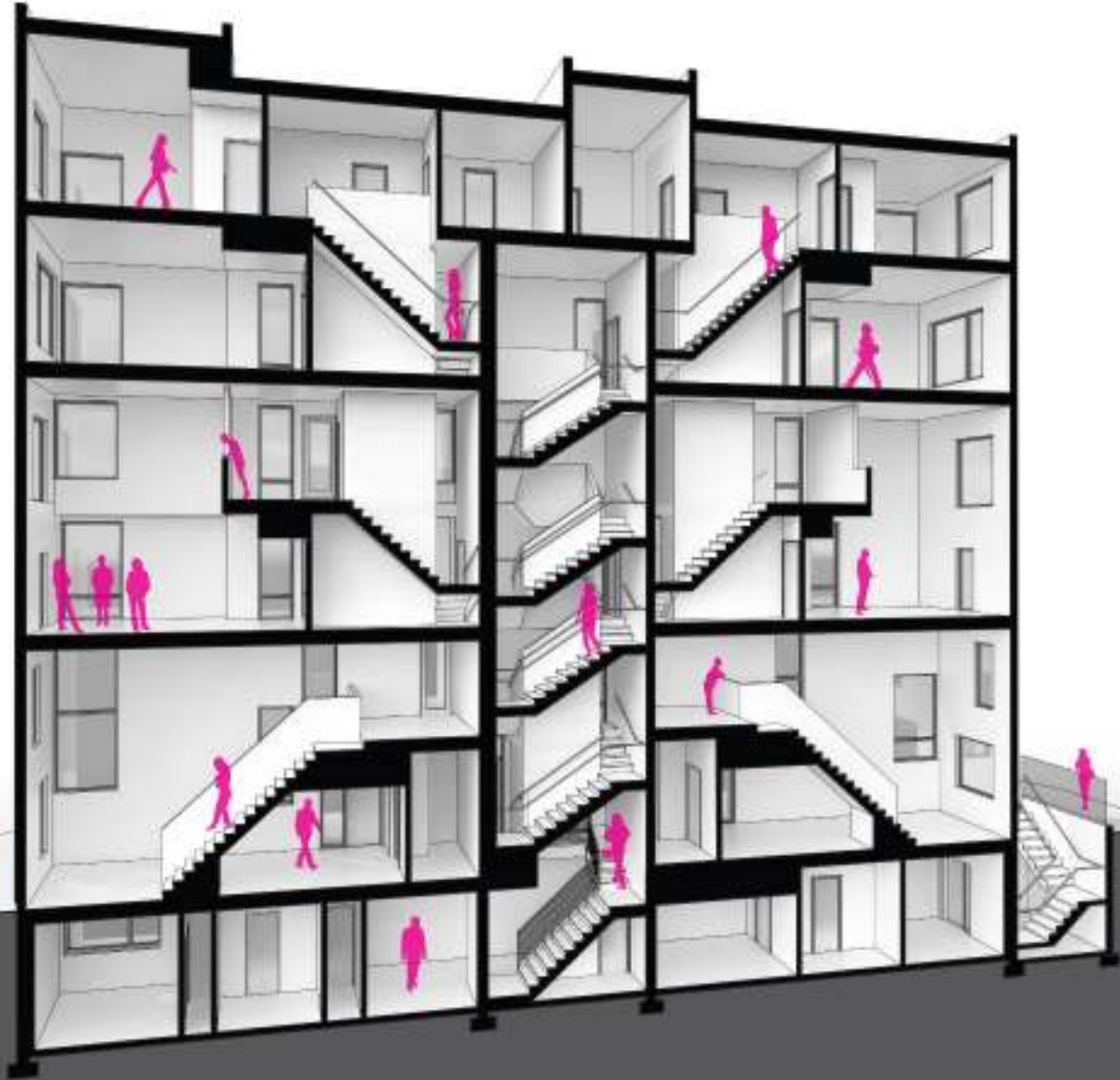

SMALL BATCH



SMALLER

**LOTS
PROJECTS
COSTS
OWNERS
BANKS
VARIANCES**

...

ISA

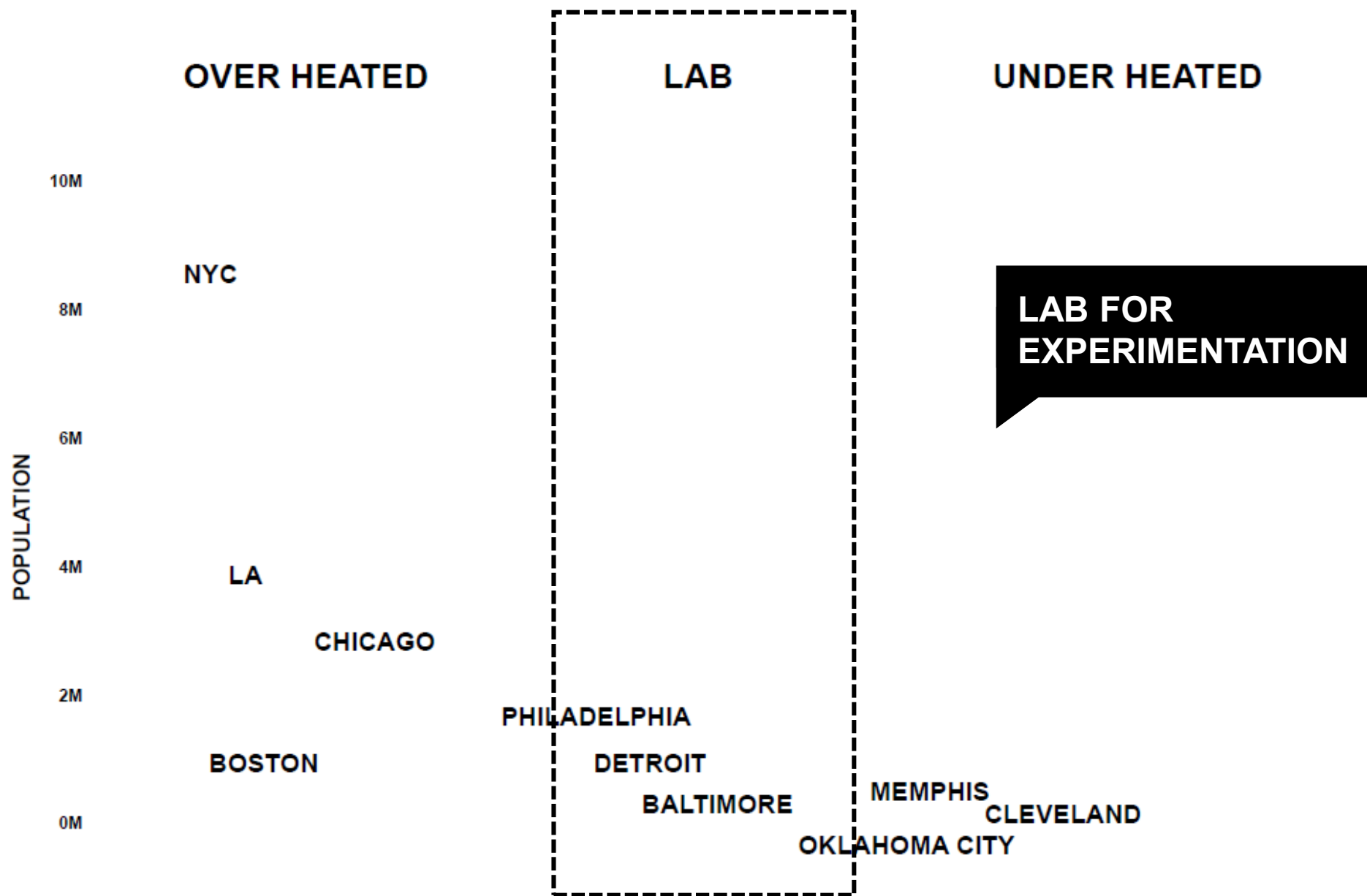

**FAVORABLE
PROCESS**

- POLITICS**
- APPROVALS**
- CONSTRUCTION**

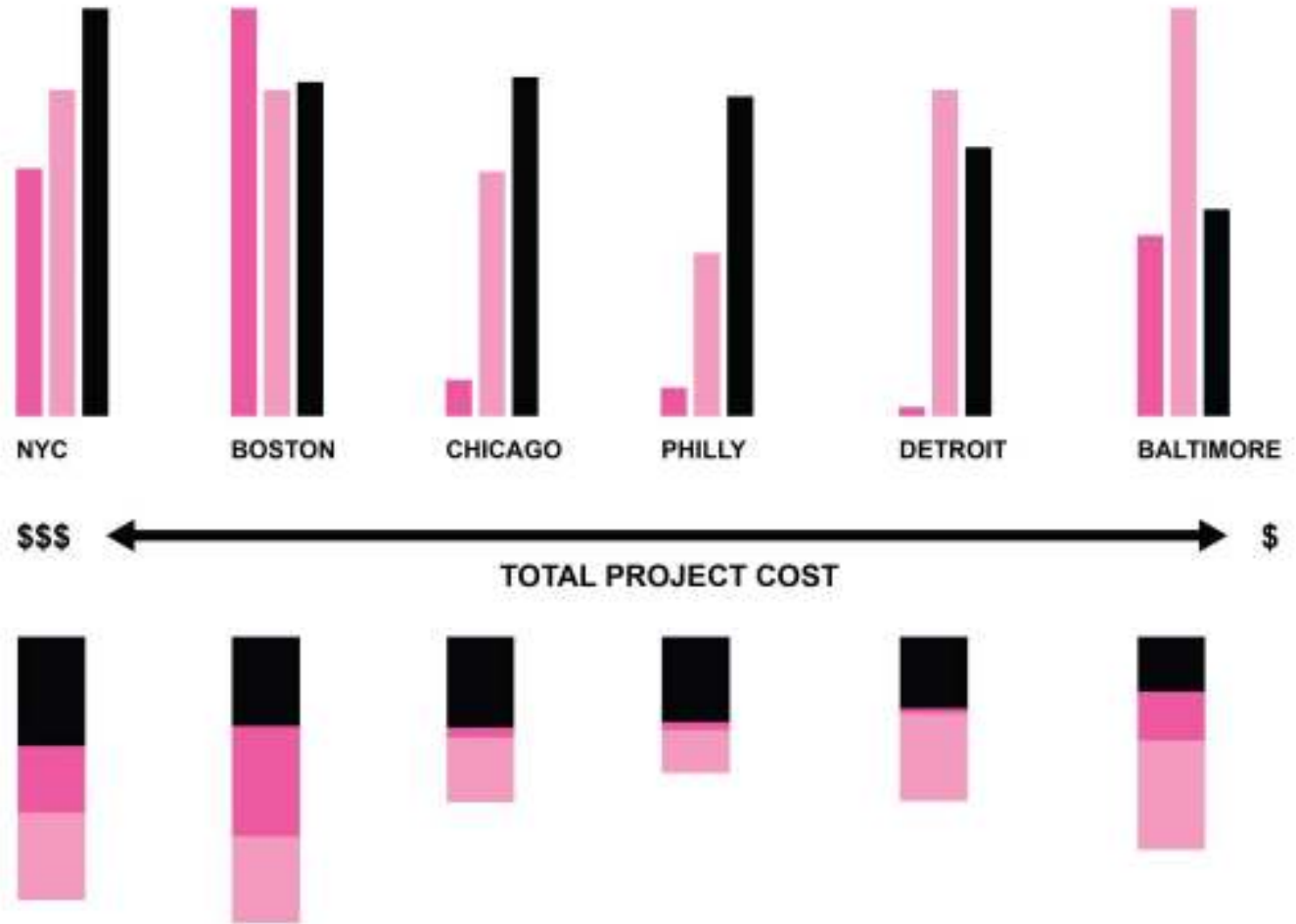

ISA

Philadelphia / Cambridge

BRIAN PHILLIPS

BRIAN@IS-ARCHITECTS.COM